

***EC3630 Radiowave Propagation***

**ANTENNAS, SYSTEMS, AND NOISE**

by Professor David Jenn

---

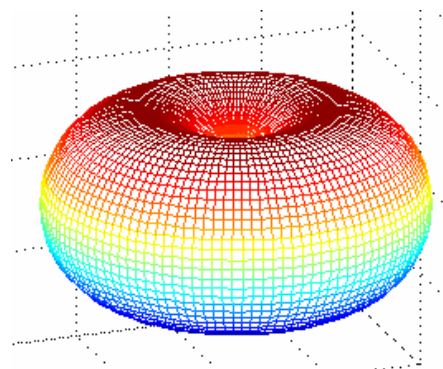

# Radiation Integrals (1)

Consider a perfect electric conductor (PEC) with an electric surface current flowing on  $S$ . In the case where the conductor is part of an antenna (a dipole), the current may be caused by an applied voltage, or by an incident field from another source (a reflector). The observation point is denoted by  $P$  and is given in terms of unprimed coordinate variables. Quantities associated with source points are designated by primes. We can use any coordinate system that is convenient for the particular problem at hand.

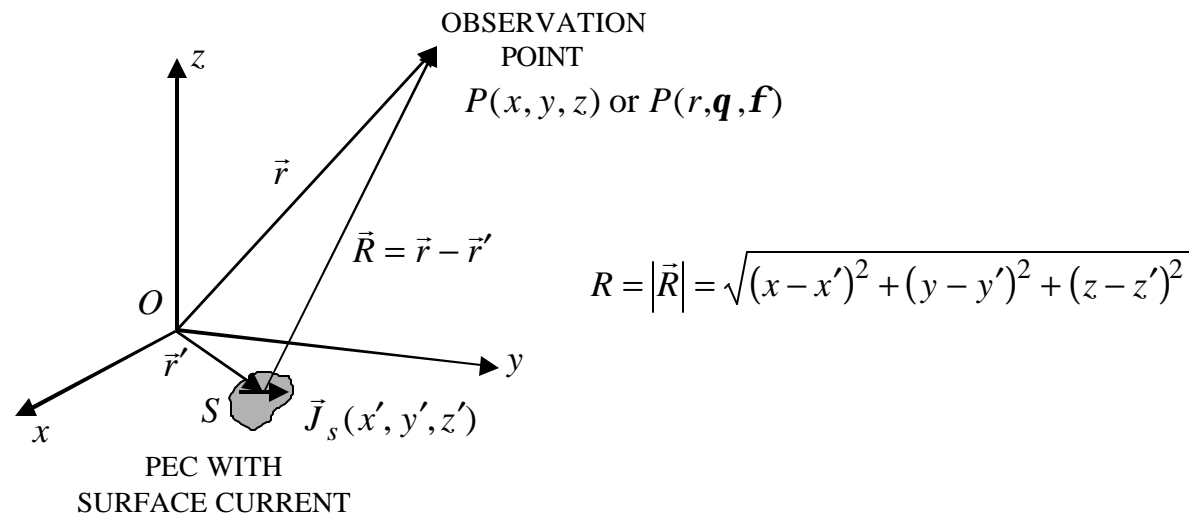

The medium is almost always free space ( $\mathbf{n}_o, \mathbf{e}_o$ ), but we continue to use ( $\mathbf{n}, \mathbf{e}$ ) to cover more general problems. If the currents are known, then the field due to the currents can be determined by integration over the surface.

# Radiation Integrals (2)

The vector wave equation for the electric field can be obtained by taking the curl of Maxwell's first equation:

$$\nabla \times \nabla \times \vec{E} = k^2 \vec{E} - j\omega \mathbf{m} \vec{J}_s$$

A solution for  $\vec{E}$  in terms of the magnetic vector potential  $\vec{A}(\vec{r})$  is given by

$$\vec{E}(\vec{r}) = -j\omega \vec{A}(\vec{r}) + \frac{\nabla(\nabla \cdot \vec{A}(\vec{r}))}{j\omega \epsilon} \quad (1)$$

where  $(\vec{r})$  is a shorthand notation for  $(x, y, z)$  and  $\vec{A}(\vec{r}) = \frac{\mathbf{m}}{4\pi} \iint_S \frac{\vec{J}_s}{R} e^{-jkR} ds'$

We are particularly interested in the case where the observation point is in the far zone of the antenna ( $P \rightarrow \infty$ ). As  $P$  recedes to infinity, the vectors  $\vec{r}$  and  $\vec{R}$  become parallel.

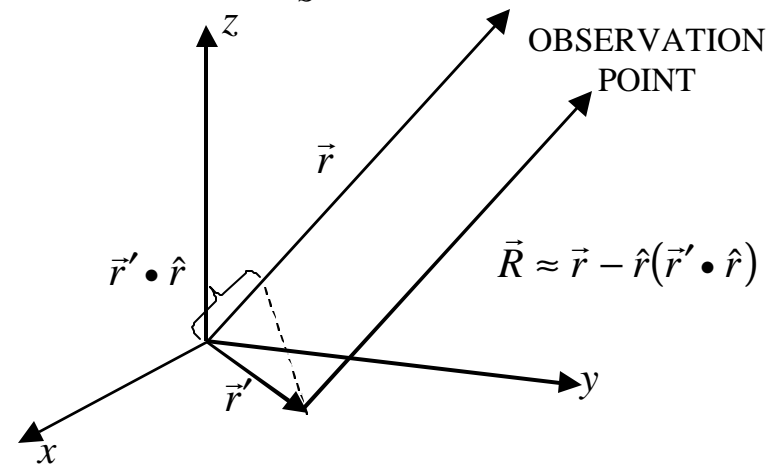

# Radiation Integrals (3)

---

In the expression for  $\vec{A}(\vec{r})$  we use the approximation  $1/R \approx 1/r$  in the denominator and  $\hat{r} \cdot \vec{R} \approx \hat{r} \cdot [\vec{r} - \hat{r}(\vec{r}' \cdot \hat{r})]$  in the exponent. Equation (2) becomes

$$\vec{A}(\vec{r}) \approx \frac{\mathbf{n}}{4\pi r} \iint_S \vec{J}_s e^{-jk\hat{r} \cdot [\vec{r} - \hat{r}(\vec{r}' \cdot \hat{r})]} ds' = \frac{\mathbf{n}}{4\pi r} e^{-jkr} \iint_S \vec{J}_s e^{jk(\vec{r}' \cdot \hat{r})} ds'$$

When this is inserted into equation (1), the del operations on the second term lead to  $1/r^2$  and  $1/r^3$  terms, which can be neglected in comparison to the  $-j\omega\vec{A}$  term, which depends only on  $1/r$ . Therefore, in the far field,

$$\vec{E}(\vec{r}) \approx \frac{-j\omega\mathbf{n}}{4\pi r} e^{-jkr} \iint_S \vec{J}_s e^{jk(\vec{r}' \cdot \hat{r})} ds' \quad (\text{discard the } E_r \text{ component}) \quad (3)$$

Explicitly removing the  $r$  component gives,

$$\vec{E}(\vec{r}) \approx \frac{-jk\mathbf{h}}{4\pi r} e^{-jkr} \iint_S [\vec{J}_s - \hat{r}(\vec{J}_s \cdot \hat{r})] e^{jk(\vec{r}' \cdot \hat{r})} ds'$$

The radial component of current does not contribute to the field in the far zone.

# Radiation Integrals (4)

---

Notice that the fields have a spherical wave behavior in the far zone:  $|\vec{E}| \sim \frac{e^{-jkr}}{r}$ . The spherical components of the field can be found by the appropriate dot products with  $\vec{E}$ . More general forms of the radiation integrals that include fictitious magnetic surface currents ( $\vec{J}_{ms}$ ) are:

$$E_q(r, \mathbf{q}, \mathbf{f}) = \frac{-jk\mathbf{h}}{4\pi r} e^{-jkr} \iint_S \left[ \vec{J}_s \cdot \hat{\mathbf{q}} + \frac{\vec{J}_{ms} \cdot \hat{\mathbf{f}}}{\mathbf{h}} \right] e^{jk\vec{r}' \cdot \hat{\mathbf{r}}} ds'$$

$$E_f(r, \mathbf{q}, \mathbf{f}) = \frac{-jk\mathbf{h}}{4\pi r} e^{-jkr} \iint_S \left[ \vec{J}_s \cdot \hat{\mathbf{f}} - \frac{\vec{J}_{ms} \cdot \hat{\mathbf{q}}}{\mathbf{h}} \right] e^{jk\vec{r}' \cdot \hat{\mathbf{r}}} ds'$$

The radiation integrals apply to an unbounded medium. For antenna problems the following process is used:

1. find the current on the antenna surface,  $S$ ,
2. remove the antenna materials and assume that the currents are suspended in the unbounded medium, and
3. apply the radiation integrals.

# Hertzian Dipole (1)

Perhaps the simplest application of the radiation integral is the calculation of the fields of an infinitesimally short dipole (also called a Hertzian dipole). Note that the criterion for short means much less than a wavelength, which is not necessarily physically short.

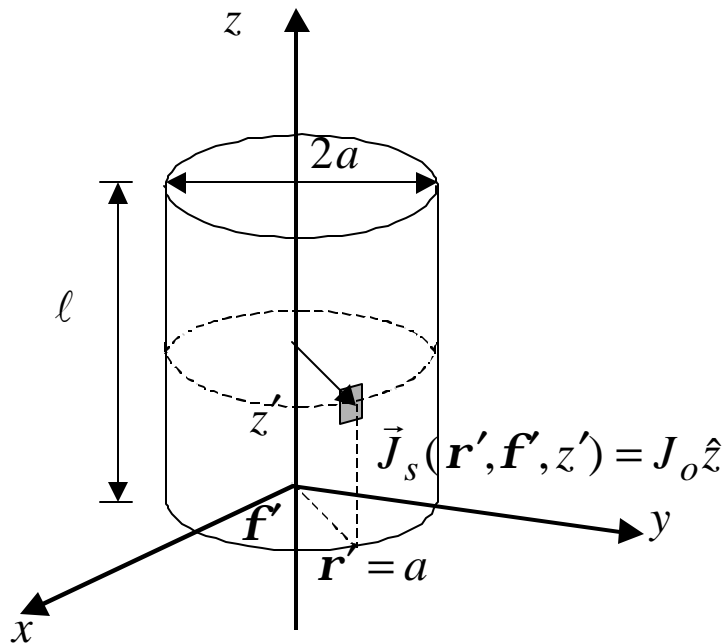

- For a thin dipole (radius,  $a \ll l$ ) the surface current distribution is independent of  $\phi'$ . The current crossing a ring around the antenna is  $I = \underbrace{|\vec{J}_s|}_{\text{A/m}} 2\pi a$
- For a thin short dipole ( $l \ll l$ ) we assume that the current is constant and flows along the center of the wire; it is a filament of zero diameter. The two-dimensional integral over  $S$  becomes a one-dimensional integral over the length,

$$\iint_S \vec{J}_s ds' \rightarrow 2\pi a \int_L I d\vec{l}'$$

# Hertzian Dipole (2)

Using  $\vec{r}' = \hat{z}z'$  and  $\hat{r} = \hat{x}\sin\mathbf{q}\cos\mathbf{f} + \hat{y}\sin\mathbf{q}\sin\mathbf{f} + \hat{z}\cos\mathbf{q}$  gives  $\vec{r}' \cdot \hat{r} = z' \cos\mathbf{q}$ . The radiation integral for the electric field becomes

$$\vec{E}(r, \mathbf{q}, \mathbf{f}) \approx \frac{-jkh}{4pr} e^{-jkr} \int_0^\ell I e^{jk(\vec{r}' \cdot \hat{r})} \frac{\hat{z} dz'}{d\vec{l}'} = \frac{-jkhI}{4pr} \hat{z} e^{-jkr} \int_0^\ell e^{jkz' \cos\mathbf{q}} dz'$$

However, because  $\ell$  is very short,  $kz' \rightarrow 0$  and  $e^{jkz' \cos\mathbf{q}} \approx 1$ . Therefore,

$$\vec{E}(r, \mathbf{q}, \mathbf{f}) \approx \frac{-jkhI}{4pr} \hat{z} e^{-jkr} \int_0^\ell (1) dz' = \frac{-jkhI\ell}{4pr} \hat{z} e^{-jkr}$$

leading to the spherical field components

$$\begin{aligned} E_{\mathbf{q}} &= \hat{\mathbf{q}} \cdot \vec{E} \approx \frac{-jkhI\ell \hat{\mathbf{q}} \cdot \hat{z}}{4pr} e^{-jkr} \\ &= \frac{jkhI\ell \sin\mathbf{q}}{4pr} e^{-jkr} \\ E_{\mathbf{f}} &= \hat{\mathbf{f}} \cdot \vec{E} = 0 \end{aligned}$$

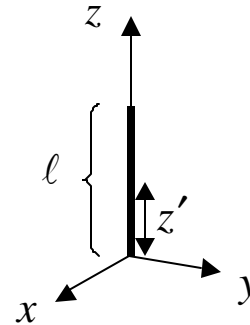

SHORT CURRENT  
FILAMENT

# Hertzian Dipole (3)

---

Note that the electric field has only a  $1/r$  dependence. The absence of higher order terms is due to the fact that the dipole is infinitesimal, and therefore  $r_{ff} \rightarrow 0$ . The field is a spherical wave and hence the TEM relationship can be used to find the magnetic field intensity

$$\vec{H} = \frac{\hat{k} \times \hat{E}}{h} = \frac{\hat{r} \times E_{\mathbf{q}} \hat{\mathbf{q}}}{h} = \hat{\mathbf{f}} \frac{jkI\ell \sin \mathbf{q}}{4\pi r} e^{-jkr}$$

The time-averaged Poynting vector is

$$\vec{W}_{\text{av}} = \frac{1}{2} \text{Re}\{\hat{E} \times \vec{H}^*\} = \frac{1}{2} \text{Re}\{E_{\mathbf{q}} H_{\mathbf{f}}^*\} \hat{\mathbf{r}} = \frac{hk^2 |I|^2 \ell^2 \sin^2 \mathbf{q}}{32\pi^2 r^2} \hat{\mathbf{r}}$$

The power flow is outward from the source, as expected for a spherical wave. The average power flowing through the surface of a sphere of radius  $r$  surrounding the source is

$$P_{\text{rad}} = \int_0^{2\pi} \int_0^{\pi} \vec{W}_{\text{av}} \cdot \hat{\mathbf{n}} ds = \frac{hk^2 |I|^2 \ell^2}{32\pi^2 r^2} \underbrace{\int_0^{2\pi} \int_0^{\pi} \sin^2 \mathbf{q} \hat{\mathbf{r}} \cdot \hat{\mathbf{r}} r^2 \sin \mathbf{q} d\mathbf{q} d\mathbf{f}}_{=8\pi/3} = \frac{hk^2 |I|^2 \ell^2}{12\pi} \text{ W}$$



# Solid Angles and Steradians

---

Plane angles:  $s = Rq$ , if  $s = R$  then  $q = 1$  radian

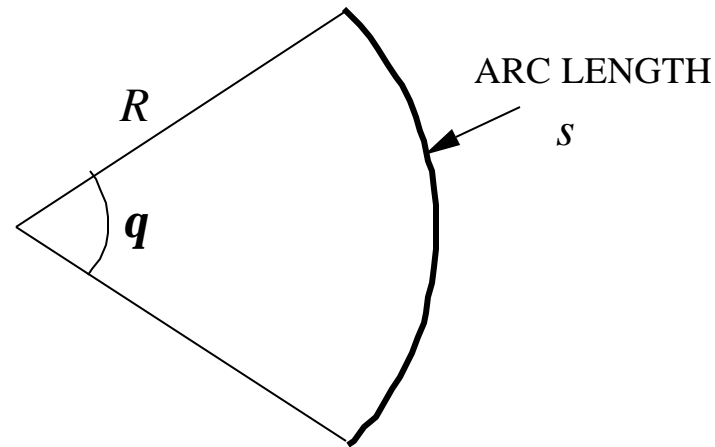

Solid angles:  $\Omega = A / R^2$ , if  $A = R^2$ , then  $\Omega = 1$  steradian

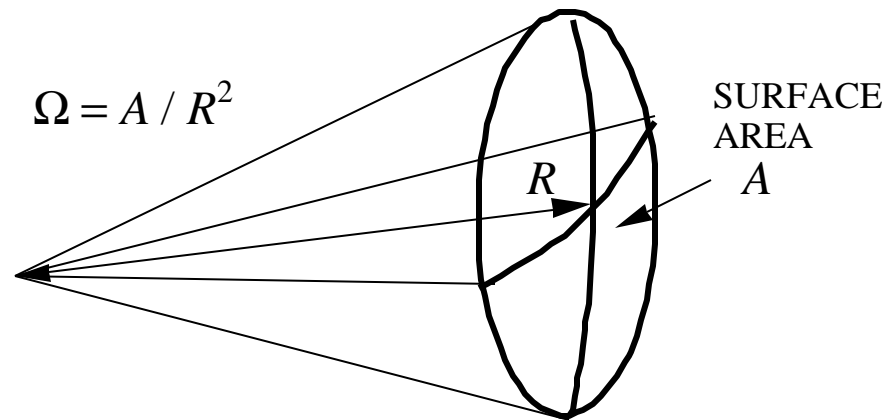

# Directivity and Gain (1)

---

The radiation intensity is defined as

$$U(\mathbf{q}, \mathbf{f}) = \frac{dP_{\text{rad}}}{d\Omega} = r^2 \hat{\mathbf{r}} \cdot \vec{W}_{\text{av}} = r^2 |\vec{W}_{\text{av}}|$$

and has units of Watts/steradian (W/sr). The directivity function or directive gain is defined as

$$D(\mathbf{q}, \mathbf{f}) = \frac{\text{power radiated per unit solid angle}}{\text{average power radiated per unit solid angle}} = \frac{dP_{\text{rad}} / d\Omega}{P_{\text{rad}} / (4\mathbf{p})} = 4\mathbf{p} \frac{r^2 |\vec{W}_{\text{av}}|}{P_{\text{rad}}}$$

For the Hertzian dipole,

$$D(\mathbf{q}, \mathbf{f}) = 4\mathbf{p} \frac{r^2 |\vec{W}_{\text{av}}|}{P_{\text{rad}}} = 4\mathbf{p} \frac{r^2 \left| \frac{\mathbf{h}k^2 |I|^2 \ell^2 \sin^2 \mathbf{q}}{32\mathbf{p}^2 r^2} \right|}{\frac{\mathbf{h}k^2 |I|^2 \ell^2}{12\mathbf{p}}} = \frac{3}{2} \sin^2 \mathbf{q}$$

The directivity is the maximum value of the directive gain

$$D_o = D_{\text{max}}(\mathbf{q}, \mathbf{f}) = D(\mathbf{q}_{\text{max}}, \mathbf{f}_{\text{max}}) = \frac{3}{2}$$

# Dipole Polar Radiation Plots

Half of the radiation pattern of the dipole is plotted below for a fixed value of  $f$ . The half-power beamwidth (HPBW) is the angular width between the half power points ( $1/\sqrt{2}$  below the maximum on the voltage plot, or  $-3\text{dB}$  below the maximum on the decibel plot).

FIELD (VOLTAGE) PLOT

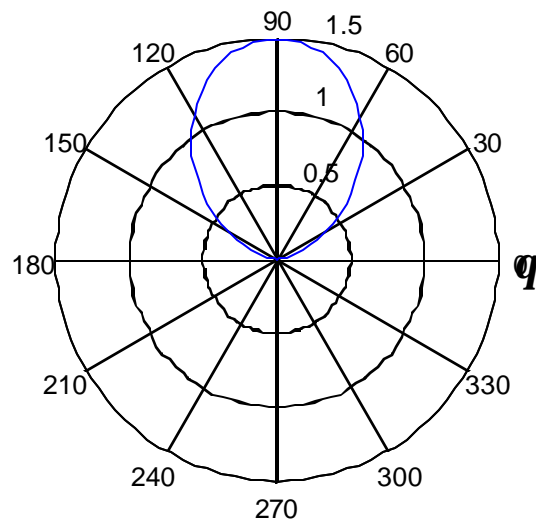

DECIBEL PLOT

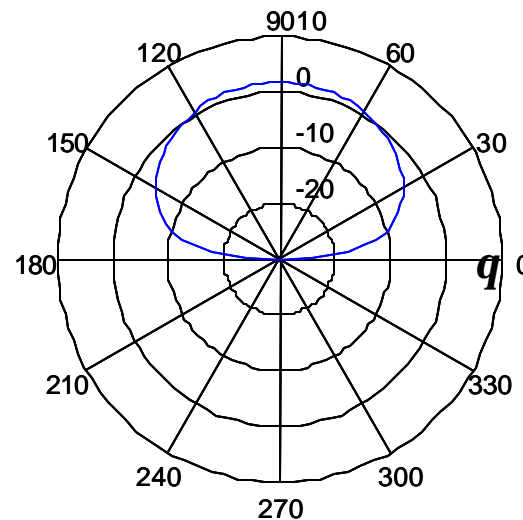

The half power beamwidth of the Hertzian dipole,  $q_B$ :

$$|E_{\text{norm}}| \sim |\sin q| \Rightarrow \sin(q_{\text{HP}}) = 0.707 \Rightarrow q_{\text{HP}} = 45^\circ \Rightarrow q_B = 2q_{\text{HP}} = 90^\circ$$

# Dipole Radiation Pattern

---

Radiation pattern of a Hertzian dipole aligned with the  $z$  axis.  $D_n$  is the normalized directivity. The directivity value is proportional to the distance from the center.

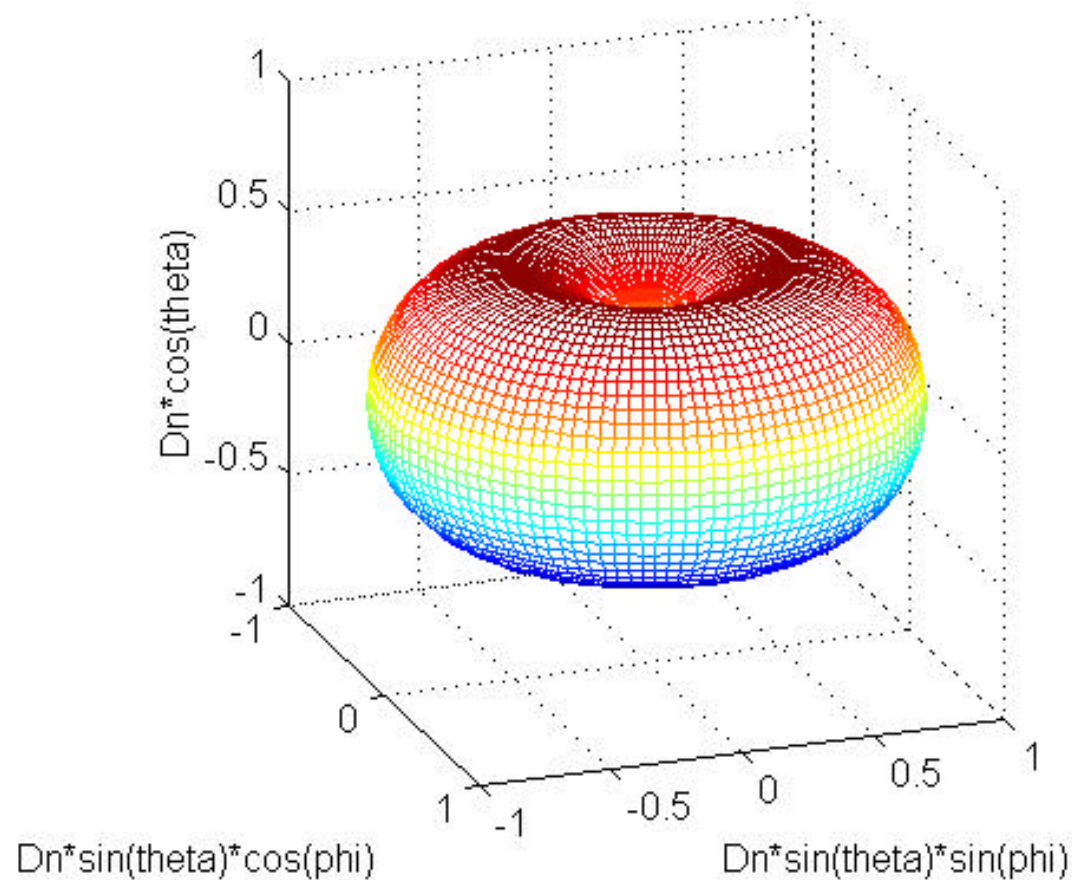

# Directivity and Gain (2)

---

Another formula for directive gain is

$$D(\mathbf{q}, \mathbf{f}) = \frac{4p}{\Omega_A} |\vec{E}_{\text{norm}}(\mathbf{q}, \mathbf{f})|^2$$

where  $\Omega_A$  is the beam solid angle

$$\Omega_A = \int_0^{2p} \int_0^p |\vec{E}_{\text{norm}}(\mathbf{q}, \mathbf{f})|^2 \sin \mathbf{q} \, d\mathbf{q} \, d\mathbf{f}$$

and  $|\vec{E}_{\text{norm}}(\mathbf{q}, \mathbf{f})|$  is the normalized magnitude of the electric field pattern (i.e., the normalized radiation pattern)

$$|\vec{E}_{\text{norm}}(\mathbf{q}, \mathbf{f})| = \frac{|\vec{E}(r, \mathbf{q}, \mathbf{f})|}{|\vec{E}_{\text{max}}(r, \mathbf{q}, \mathbf{f})|}$$

Note that both the numerator and denominator have the same  $1/r$  dependence, and hence the ratio is independent of  $r$ . This approach is often more convenient because most of our calculations will be conducted directly with the electric field. Normalization removes all of the cumbersome constants.

## Directivity and Gain (3)

---

As an illustration, we re-compute the directivity of a Hertzian dipole. Noting that the maximum magnitude of the electric field is occurs when  $\mathbf{q} = \mathbf{p} / 2$ , the normalized electric field intensity is simply

$$|\vec{E}_{\text{norm}}(\mathbf{q}, \mathbf{f})| = |\sin \mathbf{q}|$$

The beam solid angle is

$$\begin{aligned} \Omega_A &= \int_0^{2\mathbf{p}} \int_0^{\mathbf{p}} |\vec{E}_{\text{norm}}(\mathbf{q}, \mathbf{f})|^2 \sin \mathbf{q} \, d\mathbf{q} \, d\mathbf{f} \\ &= 2\mathbf{p} \underbrace{\int_0^{\mathbf{p}} \sin^3 \mathbf{q} \, d\mathbf{q}}_{=4/3} = \frac{8\mathbf{p}}{3} \end{aligned}$$

and from the definition of directivity,

$$D(\mathbf{q}, \mathbf{f}) = \frac{4\mathbf{p}}{\Omega_A} |\vec{E}_{\text{norm}}(\mathbf{q}, \mathbf{f})|^2 = \frac{4\mathbf{p}}{8\mathbf{p}/3} |\sin \mathbf{q}|^2 = \frac{3}{2} \sin^2 \mathbf{q}$$

which agrees with the previous result.

# Beam Solid Angle and Radiated Power

---

In the far field the radiated power is

$$P_{\text{rad}} = \frac{1}{2} \int_0^{2\pi} \int_0^{\pi} \underbrace{\text{Re}\{\vec{E} \times \vec{H}^*\}}_{|\vec{E}|^2 / \mathbf{h}} \cdot \hat{r} \, ds = \frac{1}{2\mathbf{h}} \underbrace{\int_0^{2\pi} \int_0^{\pi} |\vec{E}|^2 r^2 \sin \mathbf{q} \, d\mathbf{q} \, d\mathbf{f}}_{\equiv F_{\text{rad}}} \Rightarrow F_{\text{rad}} = 2\mathbf{h}P_{\text{rad}}$$

From the definition of beam solid angle

$$\begin{aligned} \Omega_A &= \int_0^{2\pi} \int_0^{\pi} |\vec{E}_{\text{norm}}(\mathbf{q}, \mathbf{f})|^2 \sin \mathbf{q} \, d\mathbf{q} \, d\mathbf{f} \\ &= \frac{1}{|\vec{E}_{\text{max}}|^2 r^2} \underbrace{\int_0^{2\pi} \int_0^{\pi} |\vec{E}|^2 r^2 \sin \mathbf{q} \, d\mathbf{q} \, d\mathbf{f}}_{\equiv F_{\text{rad}}} = \Rightarrow F_{\text{rad}} = \Omega_A |\vec{E}_{\text{max}}|^2 r^2 \end{aligned}$$

Equate the expressions for  $F_{\text{rad}}$

$$P_{\text{rad}} = \frac{\Omega_A |\vec{E}_{\text{max}}|^2 r^2}{2\mathbf{h}}$$

# Gain vs. Directivity (1)

Directivity is defined with respect to the radiated power,  $P_{\text{rad}}$ . This could be less than the power into the antenna if the antenna has losses. The gain is referenced to the power into the antenna,  $P_{\text{in}}$ .

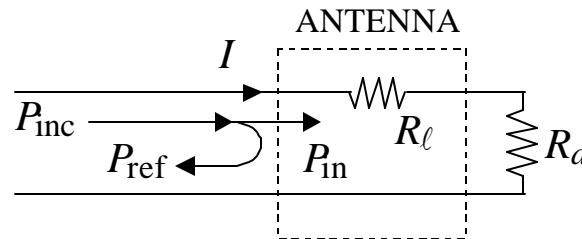

Define the following:

$P_{\text{inc}}$  = power incident on the antenna terminals

$P_{\text{ref}}$  = power reflected at the antenna input

$P_{\text{in}}$  = power into the antenna

$P_{\text{loss}}$  = power loss in the antenna (dissipated in resistor  $R_\ell$ ,  $P_{\text{loss}} = \frac{1}{2}|I|^2 R_\ell$ )

$P_{\text{rad}}$  = power radiated (delivered to resistor  $R_a$ ,  $P_{\text{rad}} = \frac{1}{2}|I|^2 R_a$ ,  $R_a$  is the radiation resistance)

The antenna efficiency,  $e$ , is  $P_{\text{rad}} = eP_{\text{in}}$  where  $0 \leq e \leq 1$ .



## Gain vs. Directivity (2)

---

Gain is defined as

$$G(\mathbf{q}, \mathbf{f}) = \frac{dP_{\text{rad}} / d\Omega}{P_{\text{in}} / (4\pi)} = 4\pi \frac{dP_{\text{rad}} / d\Omega}{P_{\text{rad}} / e} = eD(\mathbf{q}, \mathbf{f})$$

Most often the use of the term gain refers to the maximum value of  $G(\mathbf{q}, \mathbf{f})$ .

Example: The antenna input resistance is 50 ohms, of which 40 ohms is radiation resistance and 10 ohms is ohmic loss. The input current is 0.1 A and the directivity of the antenna is 2.

The input power is  $P_{\text{in}} = \frac{1}{2}|I|^2 R_{\text{in}} = \frac{1}{2}|0.1|^2 (50) = 0.25 \text{ W}$

The power dissipated in the antenna is  $P_{\text{loss}} = \frac{1}{2}|I|^2 R_{\ell} = \frac{1}{2}|0.1|^2 (10) = 0.05 \text{ W}$

The power radiated into space is  $P_{\text{rad}} = \frac{1}{2}|I|^2 R_a = \frac{1}{2}|0.1|^2 (40) = 0.2 \text{ W}$

If the directivity is  $D_o = 2$  then the gain is  $G = eD = \left( \frac{P_{\text{rad}}}{P_{\text{in}}} \right) D = \left( \frac{0.2}{0.25} \right) (2) = 1.6$

# Ground Planes and Images (1)

In some cases the method of images allows construction of an equivalent problem that is easier to solve than the original problem.

When a source is located over a PEC ground plane, the ground plane can be removed and the effects of the ground plane on the fields outside of the medium accounted for by an image located below the surface.

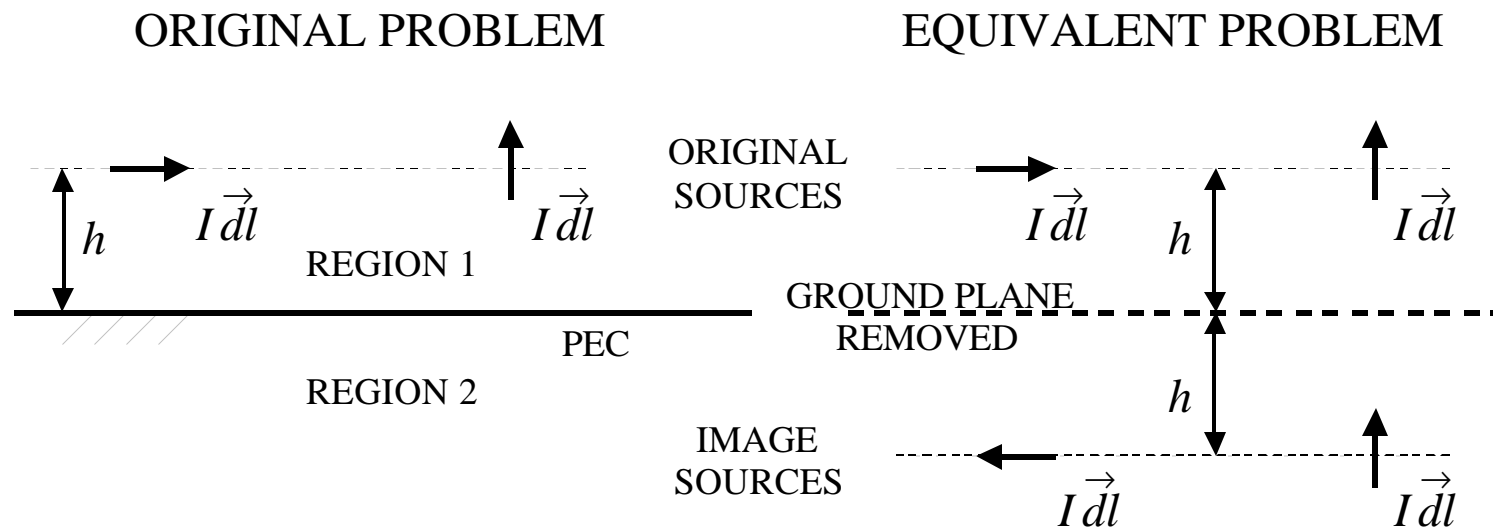

The equivalent problem holds only for computing the fields in region 1. It is exact for an infinite PEC ground plane, but is often used for finite, imperfectly conducting ground planes (such as the Earth's surface).

# Ground Planes and Images (2)

The equivalent problem satisfies Maxwell's equations and the same boundary conditions as the original problem. The uniqueness theorem of electromagnetics assures us that the solution to the equivalent problem is the same as that for the original problem.

Boundary conditions at the surface of a PEC: the tangential component of the electric field is zero.

ORIGINAL PROBLEM

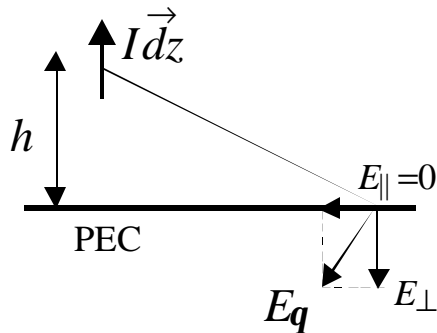

EQUIVALENT PROBLEM

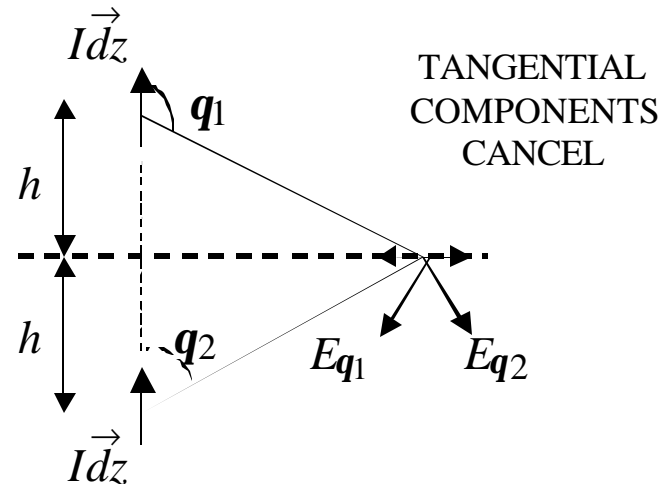

A similar result can be shown if the current element is oriented horizontal to the ground plane and the image is reversed from the source. (A reversal of the image current direction implies a negative sign in the image's field relative to the source field.)

# Ground Planes and Images (3)

Half of a symmetric conducting structure can be removed if an infinite PEC is placed on the symmetry plane. This is the basis of a quarter-wave monopole antenna.

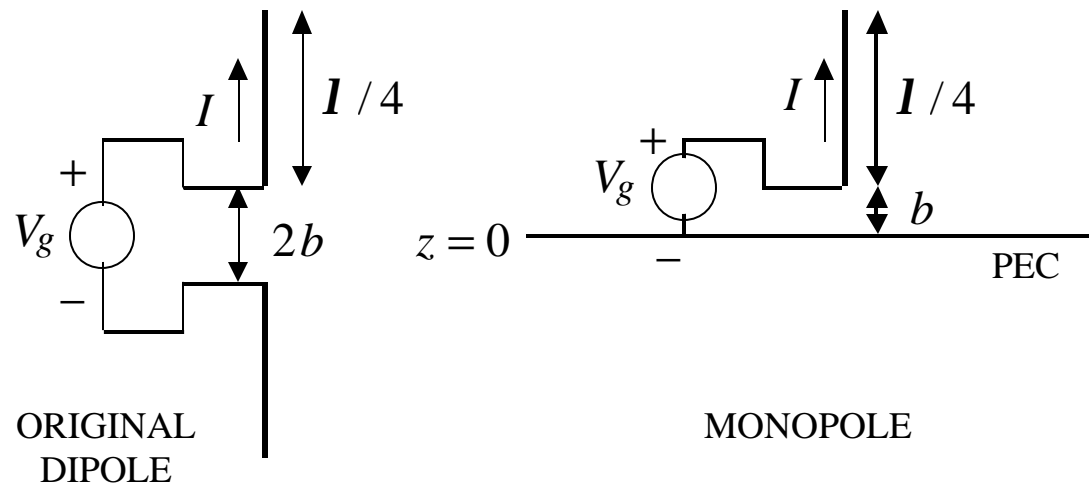

The radiation pattern is the same for the monopole as it is for the half wave dipole above the plane  $z = 0$ , the field in the monopole gap is twice the field in the gap of the dipole, and since the voltage is the same but the gap is half of the dipole's gap

$$R_a|_{\text{monopole}} = \frac{1}{2} R_a|_{\text{dipole}} = \frac{73.12}{2} = 36.56 \text{ ohms}$$

# Receiving Antennas (1)

When an antenna is receiving, it is convenient to define an effective area (or effective aperture)  $A_e$ . The power delivered to a load at the antenna terminals is

$$P_r = |\vec{W}_{inc}| A_e$$

where  $\vec{W}_{inc}$  is the incident power density.

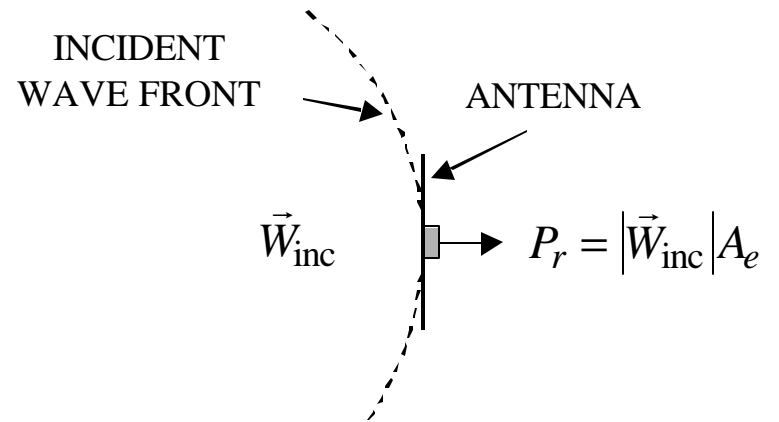

An equivalent circuit for the antenna is shown below. The current is  $I = V_{inc} / (Z_a + Z_L)$ .

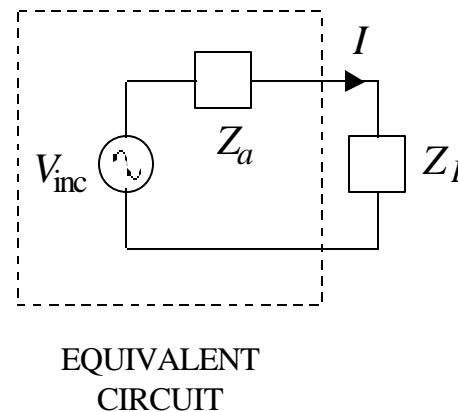
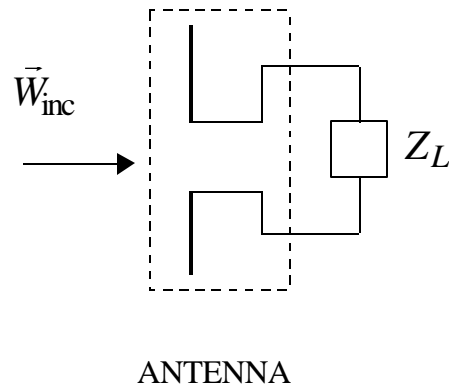

# Receiving Antennas (2)

---

Let the load be conjugate matched to the antenna impedance (which is the condition for maximum power transfer) and assume there are no losses ( $R_\ell = 0$ )

$$Z_L = Z_a^* \quad (R_L = R_a \text{ and } X_L = -X_a).$$

The equivalent circuit becomes

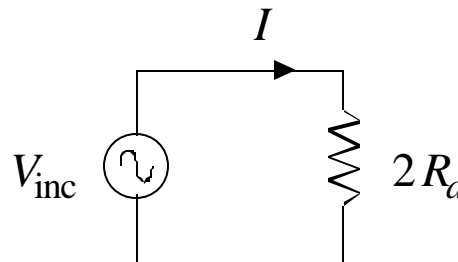

The power delivered to the receiver can be found in terms of the effective area

$$P_r = \frac{1}{2} I^2 R_a = \frac{1}{2} \frac{V_{\text{inc}}^2}{4R_a} \equiv |\vec{W}_{\text{inc}}| A_e$$

For a Hertzian dipole  $R_a = \frac{\mathbf{h}(kl)^2}{6\mathbf{p}}$ ,  $E_{\text{inc}} = V_{\text{inc}} / \ell$ , and  $|\vec{W}_{\text{inc}}| = \frac{1}{2} \frac{E_{\text{inc}}^2}{\mathbf{h}}$ . Now solve for  $A_e$ .

## Receiving Antennas (3)

---

$$A_e = \frac{1}{2} \frac{V_{\text{inc}}^2}{(4R_a) |\vec{W}_{\text{inc}}|} = \frac{1}{2} \frac{V_{\text{inc}}^2}{(4R_a) \left[ \frac{1}{2} \frac{E_{\text{inc}}^2}{\mathbf{h}} \right]} = \frac{3}{2} \frac{\mathbf{p} I^2}{(2\mathbf{p})^2} = 0.119 I^2$$

For a Hertzian dipole the directivity is  $3/2$ , and therefore the effective area can be written as

$$A_{e_m} = \frac{3}{2} \left( \frac{I^2}{4\mathbf{p}} \right) = D \left( \frac{I^2}{4\mathbf{p}} \right) \Rightarrow D = \frac{4\mathbf{p} A_{e_m}}{I^2}$$

The subscript  $m$  denotes that it is the maximum effective area because the losses are not included. If losses are included then the gain is substituted for directivity

$$A_e = G \left( \frac{I^2}{4\mathbf{p}} \right) \Rightarrow G = \frac{4\mathbf{p} A_e}{I^2}$$

The formula holds for any type of antenna that has a well-defined aperture, or surface area through which all of the radiated power flows. From the formula one can deduce that the effective area is related to the physical area  $A$  by  $A_{e_m} = eA$ .

# Polarization Loss (1)

---

For linear antennas an effective height ( $\vec{h}_e$ ) can be defined

$$V_{oc} = \vec{E}_{inc} \cdot \vec{h}_e$$

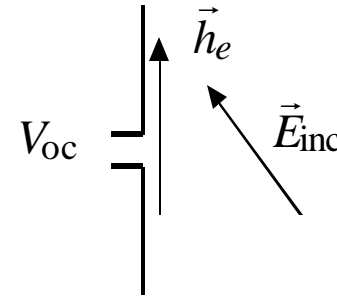

The open circuit voltage is a maximum when the antenna is aligned with the incident electric field vector. The effective height of an arbitrary antenna can be determined by casting its far field in the following form of three factors

$$\vec{E}(r, \mathbf{q}, \mathbf{f}) = [E_o] \left[ \frac{e^{-jkr}}{r} \right] [\vec{h}_e(\mathbf{q}, \mathbf{f})]$$

The effective height accounts for the incident electric field projected onto the antenna element. The polarization loss factor (PLF) between the antenna and incident field is

$$PLF, p = \frac{|\vec{E}_{inc} \cdot \vec{h}_e|^2}{|\vec{E}_{inc}|^2 |\vec{h}_e|^2}$$



# Polarization Loss (2)

Example: The Hertzian dipole's far field is

$$\vec{E}(r, \mathbf{q}, f) = \left[ \frac{j\mathbf{h}kI_o}{4\mathbf{p}} \right] \left[ \frac{e^{-jkr}}{r} \right] \underbrace{\left[ \ell \sin \mathbf{q}\hat{\mathbf{q}} \right]}_{\vec{h}_e(\mathbf{q}, f)}$$

If we have a second dipole that is rotated by an angle  $\mathbf{d}$  in a plane parallel to the plane containing the first dipole, we can calculate the PLF as follows. First,

$$V_{oc} = \vec{E}_{inc} \cdot \vec{h}_e = |\vec{E}_{inc}| \hat{z} \cdot |\vec{h}_e| \hat{z}' = |\vec{E}_{inc}| |\vec{h}_e| \hat{z} \cdot \hat{z}' = |\vec{E}_{inc}| |\vec{h}_e| \cos \mathbf{d}$$

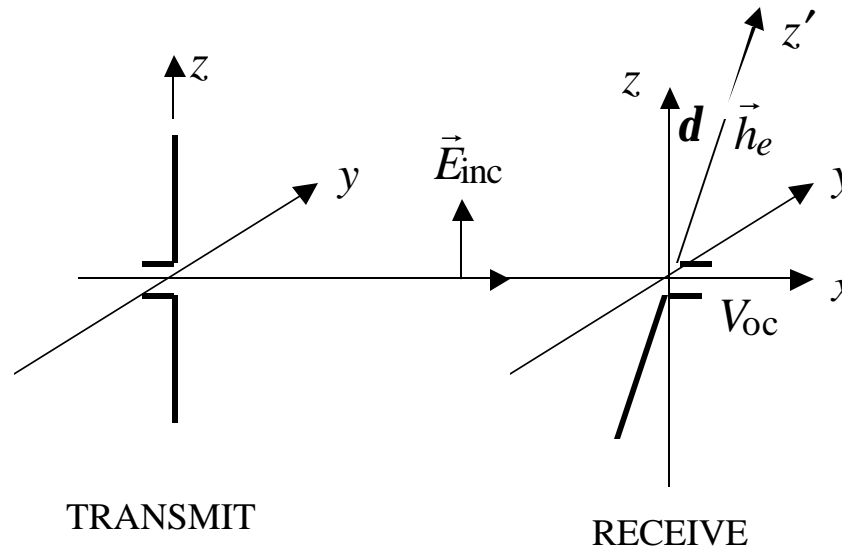

# Polarization Loss (3)

---

The PLF is

$$p = \frac{|\vec{E}_{\text{inc}} \cdot \vec{h}_e|^2}{|\vec{E}_{\text{inc}}|^2 |\vec{h}_e|^2} = \frac{|\vec{E}_{\text{inc}}|^2 |\vec{h}_e|^2 \cos^2 \mathbf{d}}{|\vec{E}_{\text{inc}}|^2 |\vec{h}_e|^2} = \cos^2 \mathbf{d}$$

When the dipoles are parallel,  $p=1$ , and there is no loss due to polarization mismatch. However, when the dipoles are at right angles,  $p=0$  and there is a complete loss of signal. A more general case occurs when the incident field has both  $\mathbf{q}$  and  $\mathbf{f}$  components

$$\vec{E}_{\text{inc}} = E_{i_q} \hat{\mathbf{q}} + E_{i_f} \hat{\mathbf{f}}$$

$$p = \frac{|(E_{i_q} \hat{\mathbf{q}} + E_{i_f} \hat{\mathbf{f}}) \cdot \vec{h}_e|^2}{|E_{i_q} \hat{\mathbf{q}} + E_{i_f} \hat{\mathbf{f}}|^2 |\vec{h}_e|^2}$$

Example: The effective height of a RHCP antenna which radiates in the  $+z$  direction is given by the vector  $\vec{h}_e = h_o (\hat{\mathbf{q}} - j\hat{\mathbf{f}})$ . A LHCP field is incident on this antenna (i.e., the incident wave propagates in the  $-z$  direction):  $\vec{E}_{\text{inc}} = E_o (\hat{\mathbf{q}} - j\hat{\mathbf{f}}) e^{jkz}$

# Polarization Loss (4)

---

The PLF is

$$p = \frac{|E_o h_o (\hat{\mathbf{q}} - j\hat{\mathbf{f}}) \bullet (\hat{\mathbf{q}} - j\hat{\mathbf{f}}) e^{jkz}|^2}{|\sqrt{2}E_o|^2 |\sqrt{2}h_o|^2} = 0$$

If a RHCP wave is incident on the same antenna, again propagating along the  $z$  axis in the negative direction,  $\vec{E}_{\text{inc}} = E_o (\hat{\mathbf{q}} + j\hat{\mathbf{f}}) e^{jkz}$ . Now the PLF is

$$p = \frac{|E_o h_o (\hat{\mathbf{q}} - j\hat{\mathbf{f}}) \bullet (\hat{\mathbf{q}} + j\hat{\mathbf{f}}) e^{jkz}|^2}{|\sqrt{2}E_o|^2 |\sqrt{2}h_o|^2} = 1$$

Finally, if a linearly polarized plane wave is incident on the antenna,  $\vec{E}_{\text{inc}} = \hat{\mathbf{q}} E_o e^{jkz}$

$$p = \frac{|E_o h_o (\hat{\mathbf{q}} - j\hat{\mathbf{f}}) \bullet \hat{\mathbf{q}} e^{jkz}|^2}{|E_o|^2 |\sqrt{2}h_o|^2} = 1/2$$

If a linearly polarized antenna is used to receive a circularly polarized wave (or the reverse situation), there is a 3 dB loss in signal.

# Example: Crossed Dipoles (1)

Crossed dipoles (also known as a turnstile) consists of two orthogonal dipoles excited 90 degrees out of phase.

$$I_x = I_o$$

$$I_y = I_o e^{j\pi/2} = jI_o$$

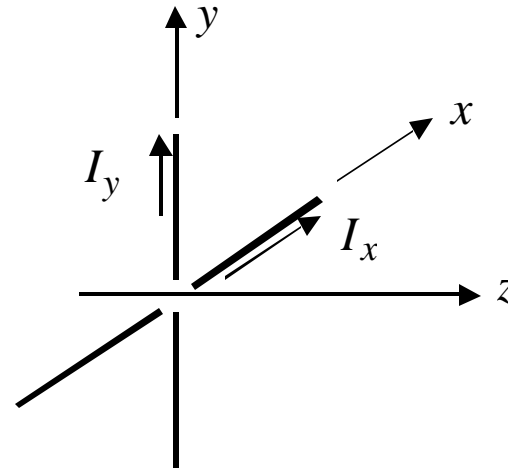

The radiation integral gives two terms

$$E_{\mathbf{q}} = \frac{-jk\mathbf{h}_o}{4\pi r} e^{-jkr} \left( \int_{-\ell/2}^{\ell/2} I_o \underbrace{\cos\mathbf{q} \cos\mathbf{f}}_{\hat{\mathbf{q}} \cdot \hat{\mathbf{x}}} e^{jx'k \sin\mathbf{q} \cos\mathbf{f}} dx' + j \int_{-\ell/2}^{\ell/2} I_o \underbrace{\cos\mathbf{q} \sin\mathbf{f}}_{\hat{\mathbf{q}} \cdot \hat{\mathbf{y}}} e^{jy'k \sin\mathbf{q} \sin\mathbf{f}} dy' \right)$$

If  $kl \ll 1$  then  $\int_{-\ell/2}^{\ell/2} e^{jx'k \sin\mathbf{q} \cos\mathbf{f}} dx' \approx \ell$  and similarly for the y integral. Therefore,

$$E_{\mathbf{q}} = \underbrace{\frac{-jk\mathbf{h}_o \ell}{4\pi}}_{\equiv E_o} \frac{e^{-jkr}}{r} \cos\mathbf{q} (\cos\mathbf{f} + j \sin\mathbf{f}) = E_o \frac{e^{-jkr}}{r} \cos\mathbf{q} (\cos\mathbf{f} + j \sin\mathbf{f})$$

## Example: Crossed Dipoles (2)

---

A similar result is obtained for  $E_f$

$$E_f = \frac{jk\mathbf{h}I_o\ell}{\underbrace{4\mathbf{p}}_{\equiv -E_o}} \frac{e^{-jkr}}{r} (\sin \mathbf{f} - j \cos \mathbf{f}) = -E_o \frac{e^{-jkr}}{r} (\sin \mathbf{f} - j \cos \mathbf{f})$$

Consider the components of the wave propagating towards an observer on the  $z$  axis  $\mathbf{q} = \mathbf{f} = 0$ :  $E_q = E_o$ ,  $E_f = jE_o$ , or

$$\vec{E} = E_o \frac{e^{-jkr}}{r} (\hat{x} + j\hat{y})$$

which is a circularly polarized wave. If the observer is not on the  $z$  axis, the projected lengths of the two dipoles are not equal, and therefore the wave is elliptically polarized. The axial ratio (AR) is a measure of the wave's ellipticity at the specified  $\mathbf{q}, \mathbf{f}$ :

$$\text{AR} = \frac{|E_{\max}|}{|E_{\min}|}, \quad 1 \leq \text{AR} \leq \infty$$

For the crossed dipoles

$$\text{AR} = \frac{|E_f|}{|E_q|} = \frac{1}{\sqrt{\cos^2 \mathbf{q} (\cos^2 \mathbf{f} + \sin^2 \mathbf{f})}} = \frac{1}{|\cos \mathbf{q}|}$$

## Example: Crossed Dipoles (3)

The rotating linear pattern is shown. A linear receive antenna rotates like a propeller blade as it measures the far field at range  $r$ . The envelope of the oscillations at any particular angle gives the axial ratio at that angle. For example, at 50 degrees the AR is about  $1/0.64 = 1.56 = 1.93$  dB.

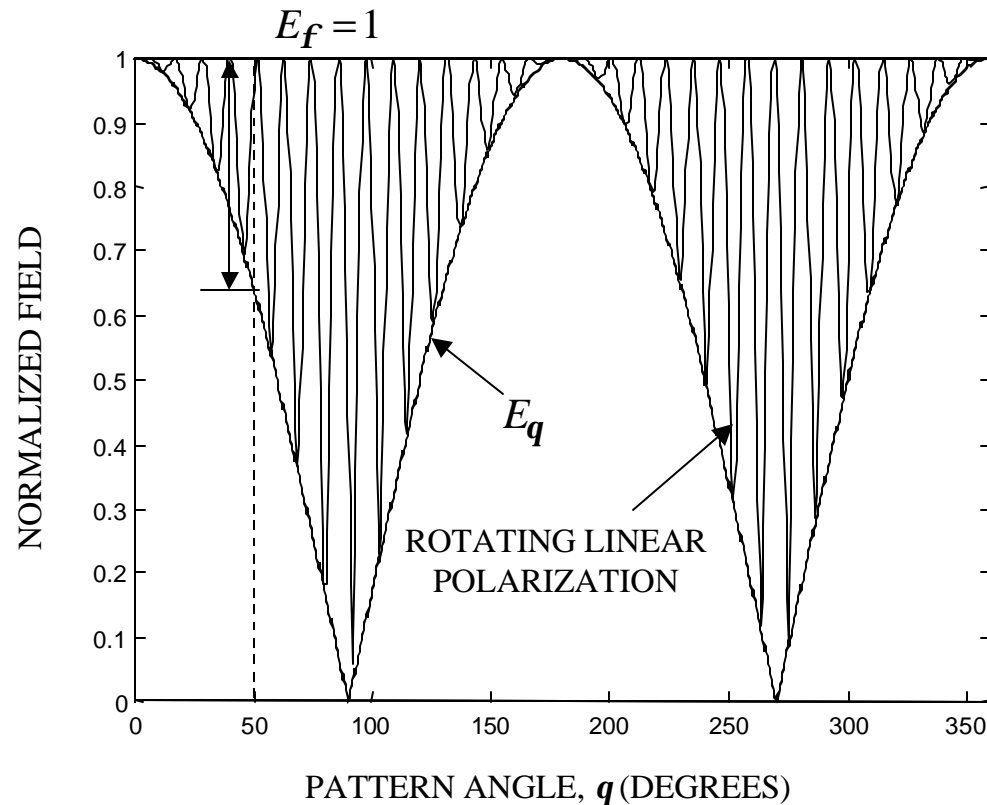

# Example: Crossed Dipoles (4)

---

Examples of rotating linear patterns on crossed dipoles that are not equal in length

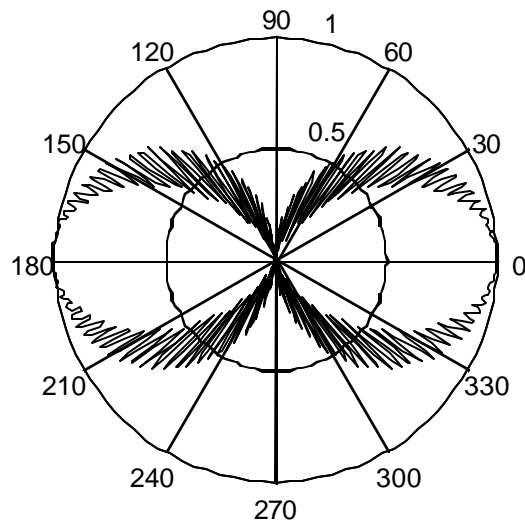

VOLTAGE PLOT

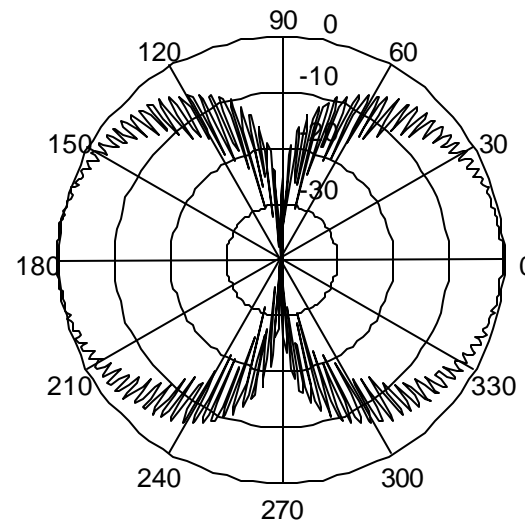

DECIBEL PLOT

# Friis Transmission Equation (1)

Consider two antennas that form a communication or data link. The range between the antennas is  $R$ . (The pattern can depend on both  $\mathbf{q}$  and  $\mathbf{f}$ , but only  $\mathbf{q}$  is indicated.)

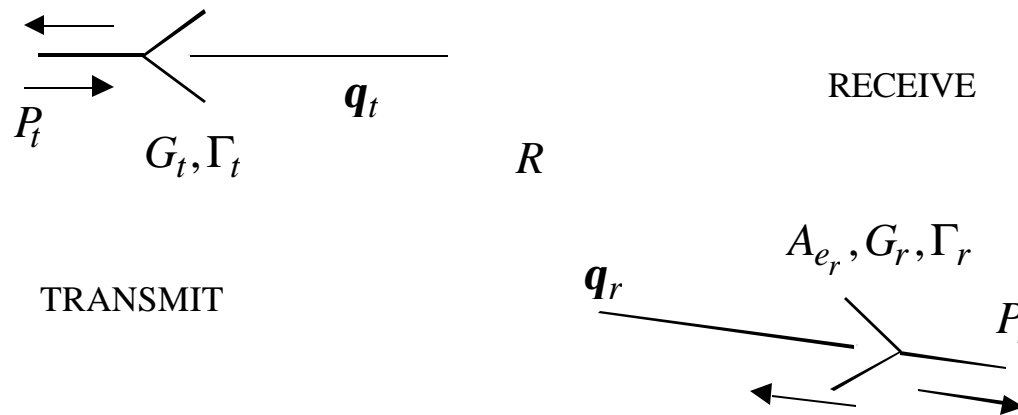

The power density at the receive antenna is

$$|\vec{W}_{\text{inc}}| = \overbrace{\frac{P_t(1 - |\Gamma_t|^2)}{4\pi R^2}}^{\text{POWER INTO ANTENNA}} G_t(\mathbf{q}_t)$$

and the received power is  $P_r = |\vec{W}_{\text{inc}}| A_{e_r}(\mathbf{q}_r) (1 - |\Gamma_r|^2) p$  ( $p$  is the polarization loss factor, PLF,  $p < 1$  if the transmit and receive polarizations are not aligned).



# Friis Transmission Equation (2)

---

But  $A_{e_r} = G_r(\mathbf{q}_r)I^2 / (4p)$ ,

$$P_r = \frac{P_t G_t(\mathbf{q}_t) G_r(\mathbf{q}_r) I^2}{(4pR)^2} (1 - |\Gamma_t|^2) (1 - |\Gamma_r|^2) pL$$

$L$  is a general loss factor ( $0 \leq L \leq 1$ ). This is known as the Friis transmission equation (sometimes called the link equation).

Example: (Satcom system) Parameters at the ground station (uplink):

$$G_t = 54 \text{ dB} = 251188.6, L = 2 \text{ dB} = 0.6310, P_t = 1250 \text{ W}$$

$$R = 23,074 \text{ miles} = 37,132 \text{ km}, f = 14 \text{ GHz}$$

At the satellite (downlink)

$$G_r = 36 \text{ dB} = 3981, P_t = 200 \text{ W}, f = 12 \text{ GHz}$$

If we assume polarization matched antennas and no reflection at the antenna inputs,

$$\begin{aligned} P_r &= \frac{(1250)(251188.6)(3981)(0.0214)^2}{(4p)^2 (37132 \times 10^3)^2} (0.6310) \\ &= 1.66 \times 10^{-9} \text{ W} = -87.8 \text{ dBw} = -57.8 \text{ dBm} \end{aligned}$$

# Radar Range Equation (1)

“Quasi-monostatic” geometry:

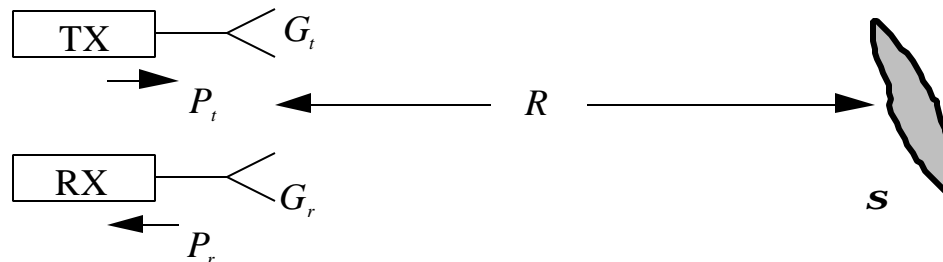

$S$  = radar cross section (RCS) in square meters

$P_t$  = transmitter power, watts

$P_r$  = received power, watts

$G_t$  = transmit antenna gain in the direction of the target (assumed to be the maximum)

$G_r$  = receive antenna gain in the direction of the target (assumed to be the maximum)

$P_t G_t$  = effective radiated power (ERP)

From antenna theory:  $G_r = \frac{4\pi A_{er}}{\lambda^2}$

$A_{er} = Ae$  = effective area of the receive antenna

$A$  = physical aperture area of the antenna

$\lambda$  = wavelength ( $c/f$ )

$e$  = antenna efficiency

# Radar Range Equation (2)

Power density incident on the target,  $\vec{W}_{inc}$

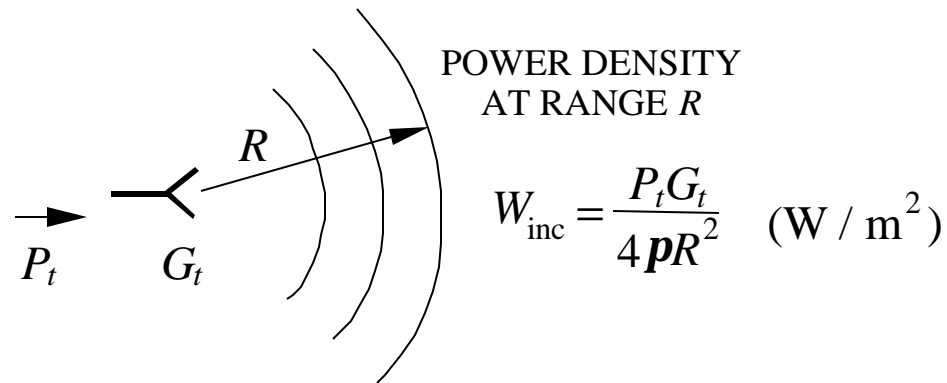

Power collected by the radar target and scattered back towards the radar

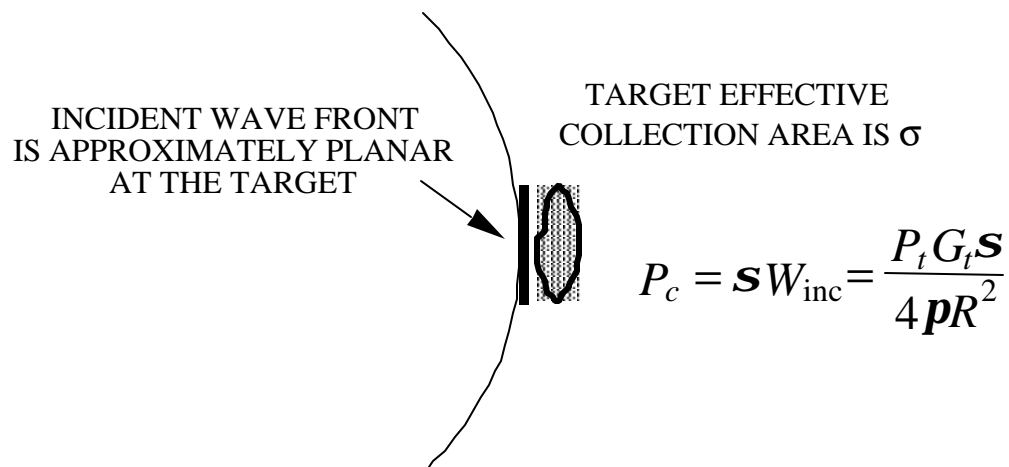

# Radar Range Equation (3)

The RCS gives the fraction of incident power that is scattered back toward the radar. Therefore,  $P_s = P_c$  and the scattered power density at the radar,  $\vec{W}_s$ , is obtained by dividing by  $4\pi R^2$ .

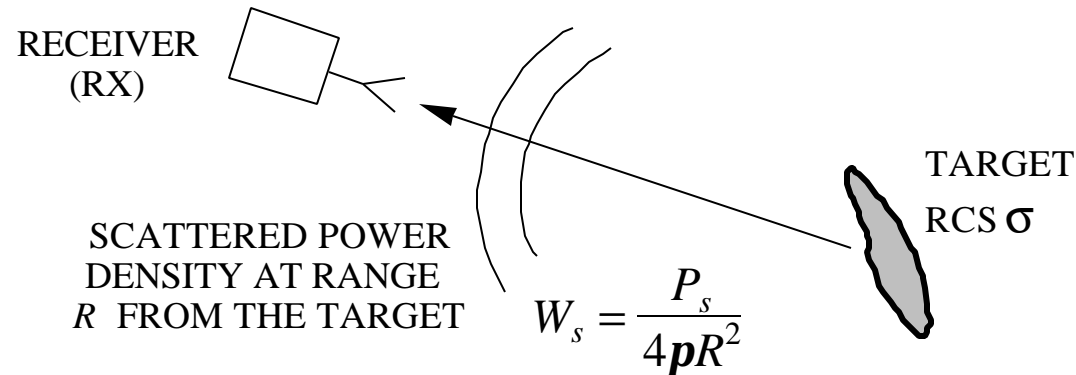

The target scattered power collected by the receive antenna is  $W_s A_{er}$ . Thus the maximum target scattered power that is available to the radar is

$$P_r = \frac{P_t G_t \sigma A_{er}}{(4\pi R^2)^2} = \frac{P_t G_t G_r \sigma l^2}{(4\pi)^3 R^4}$$

This is the classic form of the radar range equation (RRE).

# Radar Range Equation (4)

---

Including the reflections at the antenna terminals

$$P_r = \frac{P_t G_t \mathbf{s} A_{er}}{(4\pi R^2)^2} (1 - |\Gamma_t|^2) (1 - |\Gamma_r|^2) L = \frac{P_t G_t G_r \mathbf{s} I^2}{(4\pi)^3 R^4} (1 - |\Gamma_t|^2) (1 - |\Gamma_r|^2) L$$

For monostatic systems a single antenna is generally used to transmit and receive so  $G_t = G_r \equiv G$  and  $\Gamma_r = \Gamma_t$ . The above form of the RRE is too crude to use as a design tool. Factors have been neglected that have a significant impact on radar performance:

- noise,
- system losses,
- propagation behavior,
- clutter,
- waveform limitations, etc.

However, this form of the RRE does give some insight into the tradeoffs involved in radar design. The dominant feature of the RRE is the  $1/R^4$  factor. Even for targets with relatively large RCS, high transmit powers must be used to overcome the  $1/R^4$  when the range becomes large.

# Noise in Systems (1)

One way that noise enters communication and radar systems is from background radiation of the environment. (This refers to emission by the background as opposed to scattering of the system's signal by the background, which is clutter.) Noise is also generated by the components in the radar's receive channel. Under most conditions it is the internally generated thermal noise that dominates and limits the system performance.

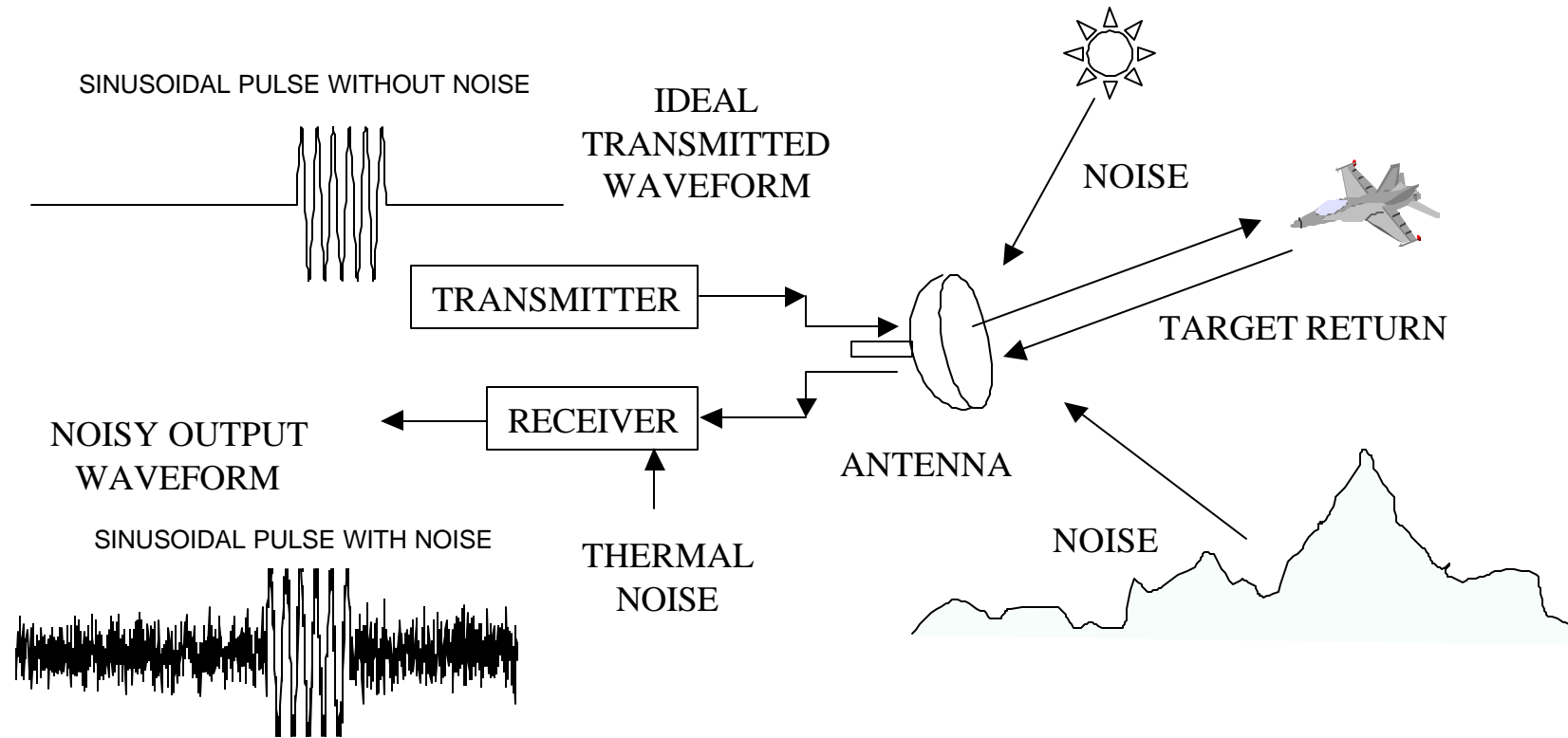

# Noise in Systems (2)

---

A high noise level will hide a weak signal and possibly cause a loss in communications or, in the case of radar, prevent detection of a target with a low radar cross section.

- Thermal noise is generated by charged particles as they conduct. High temperatures result in greater thermal noise because of increased particle agitation.
- Noise is a random process and therefore probability and statistics must be invoked to access the impact on system performance.
- Thermal noise exists at all frequencies. We will consider the noise voltage to be constant with frequency (so called white noise) and its statistics (average and variance) independent of time (stationary).

If the noise voltage generated in a resistor at temperature  $T$  Kelvin (K) is measured, it is found to obey Plank's blackbody radiation law

$$V_n = \sqrt{\frac{4hfBR}{e^{hf/kT} - 1}}$$

$h = 6.546 \times 10^{-34}$  J-sec is Plank's constant,  $k = 1.38 \times 10^{-23}$  J/°K is Boltzmann's constant,  $B$  is the system bandwidth in Hz,  $f$  is the center frequency in Hz, and  $R$  is the resistance in ohms.

# Noise in Systems (3)

At microwave frequencies  $hf \ll kT$  and the exponential can be approximated by the first two terms of a Taylor's series

$$e^{hf/kT} - 1 \approx \frac{hf}{kT}$$

and therefore,  $V_n = \sqrt{4kTB R}$ , which is referred to as the Rayleigh-Jeans approximation.

If the noisy resistor is used as a generator and connected to a second load resistor,  $R$ , the power delivered to the load in a bandwidth  $B$  is

$$N \equiv P_n = \left( \frac{V_n}{2R} \right)^2 R = \frac{V_n^2}{4R} = kTB \text{ W}$$

NOISY RESISTOR  $R$   
AT TEMPERATURE  $T$

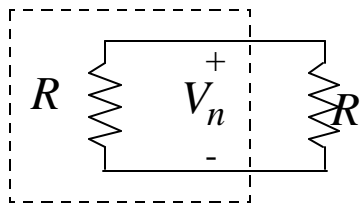

$\Rightarrow$

NOISELESS  
RESISTOR,  $R$

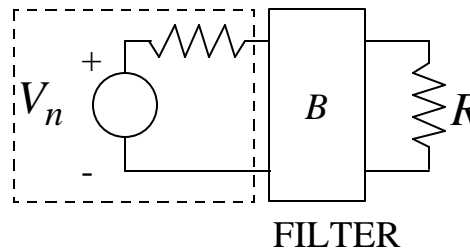

CONJUGATE MATCHED  
LOAD FOR MAXIMUM  
POWER TRANSFER



# Noise in Systems (4)

---

Limiting cases:

- $B \rightarrow 0 \Rightarrow P_n \rightarrow 0$ : Narrow band systems collect less noise
- $T \rightarrow 0 \Rightarrow P_n \rightarrow 0$ : Cooler devices generate less noise
- $B \rightarrow \infty \Rightarrow P_n \rightarrow \infty$ : Referred to as the ultraviolet catastrophe, it does not occur because noise is not really white over a wide band.

Any source of noise (for example, a mixer or cable) that has a resistance  $R$  and delivers noise power  $P_n$  can be described by an equivalent noise temperature,  $T_e$ . The noise source can be replaced by a noisy resistor of value  $R$  at temperature  $T_e$ , so that the same noise power is delivered to the load

$$T_e = \frac{P_n}{kB}$$

The noise at the antenna terminals due to the background is described by an antenna temperature,  $T_A$ . The total noise in a bandwidth  $B$  is determined from the system noise temperature,  $T_s = T_e + T_A$ :

$$N = kT_s B$$

# Calculation of Antenna Temperature

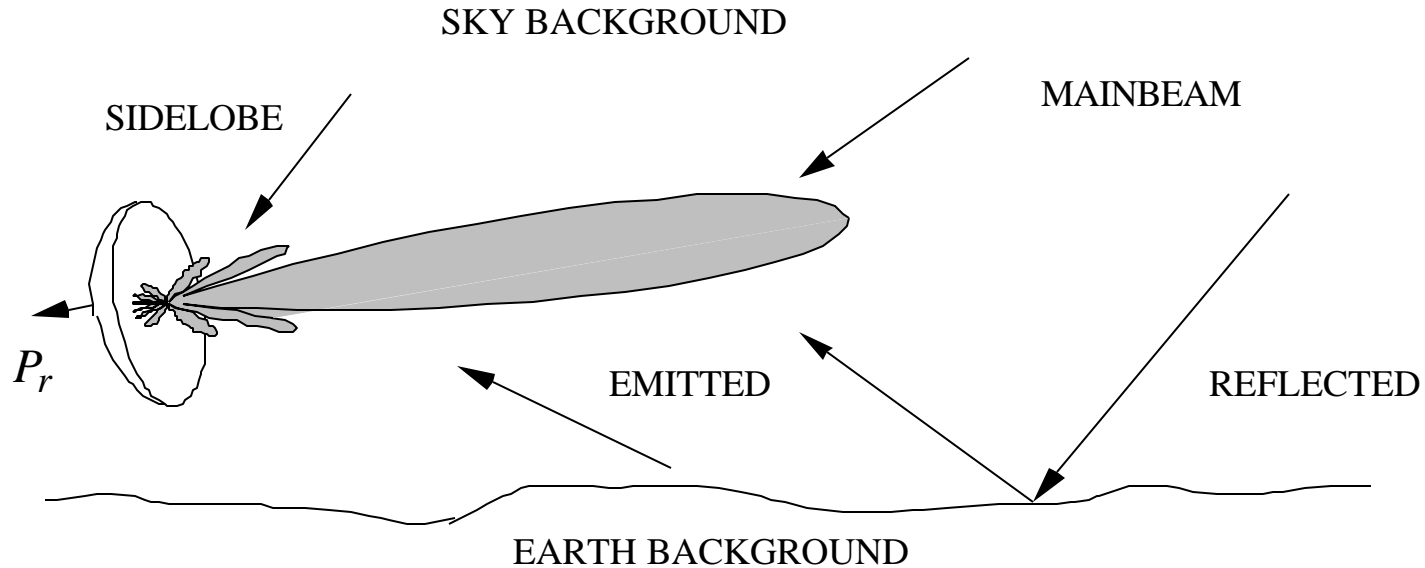

The antenna collects noise power from background sources. The noise level can be characterized by the antenna temperature

$$T_A = \frac{\int_0^p \int_0^{2p} T_B(\mathbf{q}, f) G(\mathbf{q}, f) \sin \mathbf{q} d\mathbf{q} df}{\int_0^p \int_0^{2p} G(\mathbf{q}, f) \sin \mathbf{q} d\mathbf{q} df}$$

$T_B$  is the background brightness temperature and  $G$  the antenna gain.

# Noise in Systems (5)

---

Returning to the radar range equation, we can calculate the signal-to-noise ratio (SNR)

$$\text{SNR} = \frac{P_r}{N} = \frac{P_t G_t \mathbf{s} A_{er}}{N (4pR^2)^2} L = \frac{P_t G_t G_r \mathbf{s} L^2 L}{(4p)^3 R^4 kT_s B}$$

Given the minimum SNR that is required for detection (detection threshold) it is possible to determine the maximum range at which a target can be “seen” by the radar

$$R_{\max} = \sqrt[4]{\frac{P_t G_t G_r \mathbf{s} L^2 L}{(4p)^3 (kT_s B) \text{SNR}_{\min}}}$$

Similarly, the Friis equation can be modified to give the signal-to-noise ratio

$$\text{SNR} = \frac{P_r}{N} = \frac{P_t G_t G_r \mathbf{s} L^2 L}{(4pR)^2 kT_s B}$$

# Noise Figure & Effective Temperature (1)

---

Noise figure is used as a measure of the noise added by a device. It is defined as:

$$F_n = \frac{(S/N)_{\text{in}}}{(S/N)_{\text{out}}} = \frac{S_{\text{in}} / N_{\text{in}}}{S_{\text{out}} / N_{\text{out}}} = \frac{N_{\text{out}}}{k T_o B_n G}$$

where  $G = \frac{S_{\text{out}}}{S_{\text{in}}}$ . By convention, noise figure is defined at the standard temperature of  $T_o = 290$  K. The noise out is the amplified noise in plus the noise added by the device

$$F_n = \frac{GN_{\text{in}} + \Delta N}{k T_o B_n G} = 1 + \frac{\Delta N}{k T_o B_n G}$$

$\Delta N$  can be viewed as originating from an increase in temperature. The effective temperature is

$$F_n = 1 + \frac{k T_e B_n G}{k T_o B_n G} = 1 + \frac{T_e}{T_o}$$

Solve for effective temperature in terms of noise figure yielding the relationship

$$T_e = (F_n - 1)T_o$$

# Noise Figure & Effective Temperature (2)

---

The overall noise figure for  $M$  cascaded devices with noise figures  $F_1, F_2, \dots, F_M$  and gains  $G_1, G_2, \dots, G_M$  is

$$F_o = F_1 + \frac{F_2 - 1}{G_1} + \frac{F_3 - 1}{G_1 G_2} + \dots + \frac{F_M - 1}{G_1 G_2 \dots G_{M-1}}$$

The overall effective temperature for  $M$  cascaded devices with temperatures  $T_1, T_2, \dots, T_M$  and gains  $G_1, G_2, \dots, G_M$  is

$$T_e = T_1 + \frac{T_2}{G_1} + \frac{T_3}{G_1 G_2} + \dots + \frac{T_M}{G_1 G_2 \dots G_{M-1}}$$

Example: For the receive channel shown below, the mixer has 10 dB conversion loss and 3 dB noise figure; the IF amplifier has 6 dB noise figure

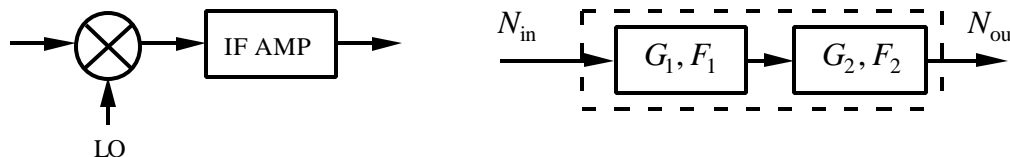

The noise figure of the dashed box is  $F_o = F_1 + \frac{F_2 - 1}{G_1} = 2 + \frac{4 - 1}{0.1} = 32$

# Example

---

A radar with the following parameters requires  $\text{SNR} = 10$  dB for a target RCS of  $5 \text{ m}^2$ :

$$G_t = 30 \text{ dB}, P_t = 200 \text{ kW}, f = 10 \text{ GHz}, B_n = 1 \text{ MHz}, T_A = 200 \text{ K}$$

The receive channel has a mixer and IF amplifier that have a combined noise figure of 15 dB. Assume cable losses of 3 dB. Find the maximum detection range for this target.

We need the system noise temperature  $T_s = T_e + T_A$ . The effective noise temperature of the receiver is  $T_e = (F_n - 1)T_o = (32 - 1)(290) = 8990 \text{ K}$ , and  $T_s = 9190 \text{ K}$ . The noise power is  $kT_s B_n = 1.27 \times 10^{-13} \text{ W}$ .

$$\text{SNR} = 10 = \frac{P_t G^2 \sigma L}{(4\pi)^3 R^4 k T_s B_n}$$

$$R^4 = \frac{(2 \times 10^5)(10^3)^2 (5)(0.03)^2 (0.5)}{(4\pi)^3 (10)(1.3 \times 10^{-13})} = 1.79 \times 10^{17}$$

or  $R = 20556 \text{ m} = 20.55 \text{ km}$  (approximately 12.7 miles)